

May 14, 1940.

E. C. DENCH

2,200,443

DISCHARGE LAMP CIRCUIT

Filed Nov. 29, 1938

*Fig. 1.*

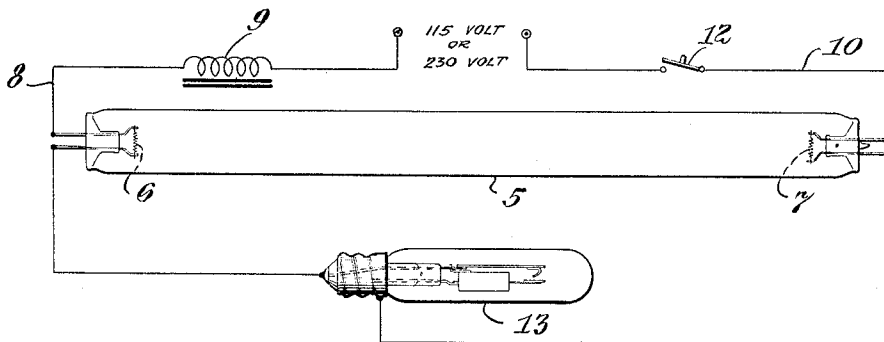

*Fig. 2.*

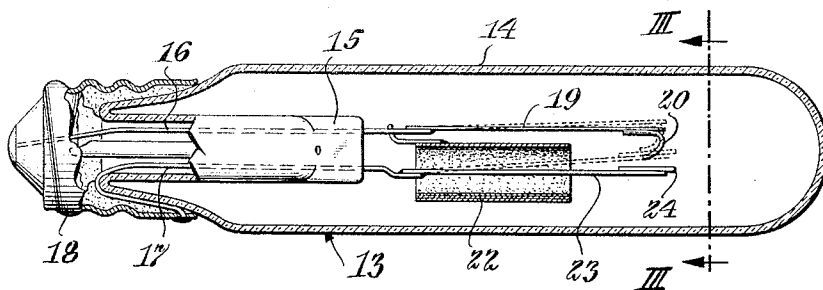

*Fig. 3.*

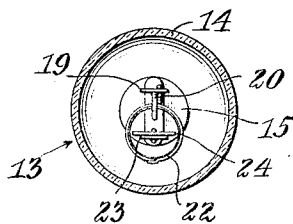

INVENTOR  
E. C. DENCH.  
BY *J. W. Greenhow*  
ATTORNEY

# UNITED STATES PATENT OFFICE

2,200,443

## DISCHARGE LAMP CIRCUIT

Edward Charles Dench, South Orange, N. J., assignor to Westinghouse Electric & Manufacturing Company, East Pittsburgh, Pa., a corporation of Pennsylvania

Application November 29, 1938, Serial No. 242,927

17 Claims. (Cl. 176—124)

The present invention relates to gaseous discharge lamps and particularly to such lamps which are operable from the usual source of electrical energy of the customary domestic potential.

5 Devices of this type are known to the art wherein a gas-filled electric discharge tube is provided with oppositely disposed filamentary electrodes which are heated from a suitable source of electrical energy to an electron emitting temperature. In the heating of these electrodes it has been found advantageous to connect the electrodes in series across the terminals of a current source and to provide some device between the terminals of the series connected electrodes to interrupt the heating current after the discharge between the electrodes has started.

10 However, the voltage necessary to strike the arc between the electrodes is ordinarily higher than that of the usual source of domestic potential, despite the fact that the electrodes are heated to an electron emitting temperature which reduces the required voltage below that otherwise necessary.

15 Various devices have heretofore been employed for the purpose of interrupting the series connected electrodes, but such devices have been subject to the disadvantage that they are not in many instances positive enough in their operation and further that such automatically responsive devices consume some power during operation, which thus decreases the efficiency of the system.

20 It is accordingly an object of the present invention to provide a gaseous electric discharge lamp which can be readily operated from the customary source of domestic potential and wherein an automatically responsive device is employed to facilitate starting of the lamp, which device is positive in its operation and consumes no power during operation of the lamp, thus increasing the efficiency of the system.

25 Another object of the present invention is the provision of a starting circuit for a gaseous electric discharge lamp having series connected filamentary electrodes and wherein an automatically responsive device is employed to interrupt the series connection of the electrodes and facilitate starting of a discharge after which the device consumes no electrical energy, thus increasing the efficiency of the circuit.

30 Another object of the present invention is the provision of an automatic responsive device for interrupting an electrical circuit, which device is accurately responsive to predetermined conditions and which operates with fidelity upon the occurrence of such conditions.

Still further objects of the present invention will become obvious to those skilled in the art by reference to the accompanying drawing wherein:

5 Fig. 1 is a diagrammatical illustration of an electrical circuit for starting and operating a gaseous electric discharge lamp in accordance with the present invention;

10 Fig. 2 is a sectional view on an enlarged scale of an automatically responsive device constructed in accordance with the present invention for interrupting the flow of electrical current as in the circuit shown in Fig. 1, and

15 Fig. 3 is a sectional view taken on the line III—III of Fig. 2 and looking in the direction indicated by the arrows.

Referring now to the drawing in detail, a gaseous electric discharge device 5 is shown which is provided with oppositely disposed filamentary electrodes 6 and 7 of a refractory metal, such as tungsten or the like, in the form of a coiled coil coated with an electron emissive material, such as an oxide of barium, strontium, or the like, to provide a copious flow of electrons when heated. After evacuation the lamp is filled with a rare gas at a few millimeters pressure to facilitate starting, to which is added a few drops of mercury.

20 As shown in Fig. 1, one terminal of the electrode 6 is connected by a conductor 8 through an inductance element 9 to one side of the source of supply of the customary domestic potential of 115 or 230 volts. Likewise, one terminal of the electrode 7 is connected by a conductor 10 and switch 12 to the opposite side of the domestic source of supply.

25 The remaining terminal of each electrode is connected together through the medium of an automatically responsive device 13 in the form of an auxiliary discharge tube so that initially the electrodes 6 and 7 are in series with each other and the source of supply so that the electrodes are heated to an electron emitting temperature. When the temperature of the electrodes reaches a value sufficient to cause a copious flow of electrons, a discharge between the electrodes follows with the device 13 automatically operating to interrupt the series heating circuit for the electrodes.

30 The system thus far described does not differ materially from the prior art with the exception of the construction and operation of the automatically responsive device 13. As shown more

35 40 45 50 55

in detail in Figs. 2 and 3, this device or auxiliary discharge tube comprises a vitreous envelope or the like 14 having a gaseous environment therein, such as neon, argon, or a similar ionizable medium. The envelope 14 is provided with a re-entrant press 15 having a pair of leading-in and supporting conductors 16 and 17 sealed there-through and connected to a suitable base 18 for the device.

10 Interiorly of the device 13 and welded or otherwise rigidly affixed to the leading-in conductor 16 is a bimetal strip 19 to the extremity of which is welded or otherwise secured an angularly extending contact 20 which may be of any suitable metal, such for example as nickel, silver, tungsten or the like. Also welded or otherwise rigidly secured to the leading-in conductor 16 is a metallic cylinder of nickel, iron, molybdenum or the like, coated interiorly with an electron 15 emissive material, such as the oxides of barium, strontium, etc., and thus constituting a cathode electrode 22 during a portion of the alternating current cycle.

A second bimetallic strip 23 is welded or otherwise rigidly fastened to the leading-in conductor 25 17 and is disposed concentric with the cylinder or cathode 22 and thus constitutes the anode electrode during the same portion of the alternating current cycle as when the cylinder 22 and bimetallic element 19 are instantaneously cathode. During the reverse half wave the bimetallic element 23 functions as cathode, and emits electrons due to the electron emissive material sputtered thereon from the cylinder 22, and the latter together with the bimetallic element 19 35 functions as anode. A suitable contact 24, such as a plate of molybdenum or tungsten, is rigidly secured to the extremity of the bimetallic strip 23 adjacent the contact 20, so that the latter is centrally located when engaging the plate contact 40 24, and in the open position of the contact terminals 20 and 24, their spacing and the pressure of the gaseous filling is such that an arc starts within the device 13 when the applied voltage is approximately 90 to 100 volts.

The operation of the system shown in Fig. 1 and the automatically responsive device of Figs. 2 and 3 is as follows: the switch 12 is first closed, thus connecting the lamp 5 together with the 50 various other elements to the source of electrical energy of the customary potential of 115 or 230 volts. Current will then flow from the source of supply through the inductance element 9, the electrode 6, automatically responsive device 13 55 and electrode 7, back to the source of supply.

Since the spacing of the electrodes of the device 13 and the pressure of the gas therein is such that a voltage of from 90 to 100 volts will cause breakdown thereof, and the voltage of the source 60 is 115 volts or more, a discharge immediately occurs between the cylinder 22 functioning as cathode and the bimetallic element 23 operating as anode, or vice versa, depending on the half wave of the alternating current cycle, with resultant 65 current flow in the manner just mentioned.

After the lapse of a few seconds the resulting glow discharge between the electrodes 22 and 23 of the automatically responsive device 13 heats the bimetallic element or anode 23, causing the 70 same to flex in the manner shown in dotted lines in Fig. 2 and the contact terminals 20 and 24 to close. This extinguishes the discharge since the current seeks the path of least resistance through the bimetallic element 19 which is of the 75 same instantaneous polarity as the cathode 22,

and the flow of current therethrough heats the electrodes 6 and 7 of the lamp 5, which causes ionization of the gas in the vicinity of each electrode.

Again, however, after the lapse of but a few 5 seconds the bimetallic element 23 cools, causing it to flex back to its original position, as shown in Fig. 2, thus breaking the connection between contacts 20 and 24 and interrupting the heating circuit for the series connected electrodes 6 and 7. 10 Interruption of the heating circuit causes an inductive voltage surge which, being higher than the voltage of the source, is sufficient to strike an arc in the partially ionized gas between the electrodes 6 and 7 because the breakdown voltage 15 of the lamp 5 at such instant is less than that of the device 13. During continuance of the resulting discharge in the lamp 5, the electrodes 6 and 7 require no further heating from the source of supply as they are maintained at an electron 20 emitting temperature due to electron and positive ion bombardment, so that the lamp continues to operate until the switch 12 is opened and the device 13 is thus shunted from the discharge circuit. 25

It will thus be seen that the automatically responsive device 13 is exceptionally positive in its operation. After completing its cycle of operation, as above mentioned, which altogether consumes but a few seconds, should the lamp 5 for 30 any reason fail to start, the device 13 merely continues its cycle of operation until the arc strikes between the electrodes.

If desired, the shield 22 may be entirely dispensed with, in which event both bimetallic elements 19 and 23 are provided with an electron 35 emissive material. Such elements may also be made to flex in opposite directions, since both are thus heated directly by the resulting discharge, whereas in the structure as shown in Fig. 2, most of the flexing is done by the element 23 40 due to the element 19 being shielded by the cylinder 22. In addition, only one bimetallic element may be employed as an electrode, although it may be preferable to have both electrodes bimetallic 45 to compensate for ambient temperature conditions.

Thus the automatically responsive device 13 is first heated by the discharge occurring between the electrodes, which electrodes themselves are 50 bimetallic elements. Upon heating the electrodes to a predetermined temperature, the elements or electrodes extinguish the discharge by short circuiting the discharge path and, upon cooling of the electrodes, their engagement is broken to condition the device for repetition of its cycle of operation. Moreover, the device consumes energy 55 only during the initial moment of its operation when the glow discharge is initiated, and thereafter all the energy supplied by the source flows through the device to the load. 60

In the case shown in Fig. 1 wherein the load constitutes series connected electrodes, energy loss is thus confined to a minimum so that substantially all of the available energy is supplied 65 to the electrodes. Also, upon breaking of the contacts of the device to initiate a discharge in the lamp and to interrupt the series connection of the electrodes, the automatically responsive device still continues to consume no energy from the 70 source.

It accordingly becomes obvious to those skilled in the art that a circuit for a gaseous electric discharge lamp is herein provided wherein an automatically responsive device connects the elec- 75

trodes in a series circuit for the purpose of heating the electrodes to an electron emitting temperature. After the electrodes have been heated to a predetermined temperature, the automatically responsive device functions to interrupt the heating circuit and maintain it in such condition, which device consumes no energy except during a very brief moment of its initial operation. Moreover, the device is heated entirely by the resulting discharge occurring in the device, which discharge is between bimetallic electrodes operable to extinguish the arc upon the electrodes becoming heated.

Although but one embodiment of the present invention has been herein shown and described, it is to be understood that other modifications thereof may be made without departing from the spirit and scope of the appended claims.

I claim:

1. The combination of a gaseous electric discharge lamp provided with electrodes adapted to be heated to an electron emitting temperature, a readily ionizable medium therein, a source of electrical energy for heating the said electrodes and for energizing said lamp, an inductance element interposed between said source and one of said electrodes, and an auxiliary discharge device provided with electrodes therein between which a discharge occurs upon the application of a potential from said source and having a bimetallic element therein heated by the discharge and operable to extinguish said discharge and initially connect the electrodes of said lamp in a heating circuit with said source and to thereafter interrupt said heating circuit and cause an attendant voltage surge from said inductance element for initiating a discharge in said lamp.

2. The combination of a gaseous electric discharge lamp provided with electrodes therein adapted to be heated to an electron emitting temperature from a source of electrical energy and having a filling of a readily ionizable medium, a source of electrical energy connected to one of the electrodes of said lamp, an inductance element connected to said source and to the other of said electrodes, and an auxiliary discharge device provided with electrodes connected to the electrodes of said lamp and between which a discharge occurs upon the application of a potential thereto from said source, said device including a bimetallic element disposed therein and heated by the ensuing discharge to cause extinguishment of the discharge and operable to connect the electrodes of said lamp to said source for heating the same to an electron emitting temperature, and said bimetallic element being operable upon cooling thereof to interrupt the heating circuit for the electrodes of said lamp and to cause an attendant voltage surge from said inductance element for initiating a discharge in said lamp.

3. The combination with a gaseous electric discharge lamp provided with thermionic electrodes therein including filaments which emit a copious flow of electrons when heated, of a starting and operating circuit for said lamp comprising a source of electrical energy connected to one terminal of one of said electrodes, an inductance element connected to said source and to one terminal of the other of said electrodes, and means interconnecting the remaining terminals of each of said electrodes to complete a series heating circuit therefor from said source, said means including an auxiliary gaseous discharge device having electrodes therein between which a dis-

charge occurs, one of said electrodes being a bimetallic element heated by the discharge to close the series heating circuit for the electrodes of said lamp and to extinguish the discharge in said device, and said bimetallic electrode being operable upon cooling to interrupt said series heating circuit upon the electrodes of said lamp reaching an electron emitting temperature and to cause an attendant voltage surge from said inductance element for initiating a discharge in said lamp.

4. The combination of a gaseous electric discharge lamp provided with electrodes therein adapted to be heated to an electron emitting temperature from a source of electrical energy and having a filling of a readily ionizable medium, a source of electrical energy for energizing said lamp, an inductance element connected to said source and to said lamp, and an automatically responsive device comprising a container provided with an ionizable medium therein and a pair of electrodes, one of which is a bimetallic element and between which a discharge occurs upon the application of a potential from said source, and contacts carried by the electrodes of said device and connected to the electrodes of said lamp and operable to engage each other upon said bimetallic electrode being heated by the discharge to connect the electrodes of said lamp in series with each other and with said source, and said bimetallic electrode being operable to interrupt said series connection upon cooling thereof to cause an attendant voltage surge from said inductance element for initiating a discharge in said lamp.

5. The combination of a gaseous electric discharge lamp provided with electrodes therein adapted to be heated to an electron emitting temperature from a source of electrical energy and having a filling of a readily ionizable medium, a source of electrical energy for energizing said lamp, an inductance element connected to said source and to said lamp, and an automatically responsive device operable to connect said electrodes in a series circuit with each other and with said source for heating said electrodes to an electron emitting temperature and for thereafter interrupting said series circuit for said electrodes to cause the initiation of a discharge therebetween, said device comprising a container provided with an ionizable medium therein and a pair of electrodes, one of which is a bimetallic element and between which a discharge occurs upon the application of a potential from said source, and contacts carried by the electrodes of said device and connected to the electrodes of said lamp and operable to engage each other upon said bimetallic element being heated by the discharge to close said series circuit and for interrupting said circuit upon cooling of said bimetallic electrode to cause an attendant voltage surge from said inductance element for initiating a discharge in said lamp.

6. A gaseous electric discharge device comprising a container provided with an ionizable medium therein, electrodes disposed within said container, one of said electrodes being adapted to emit electrons, and between which a glow discharge occurs upon the application of a potential thereto, and a bimetallic element in said container adapted to be heated by the ensuing discharge and operable to short-circuit said electrodes and extinguish said discharge.

7. A gaseous electric discharge device comprising a container provided with an ionizable me-

dium therein, electrodes disposed in said container, one of said electrodes being adapted to emit electrons, and between which a discharge occurs upon the application of a relatively low potential thereto, and one of said electrodes being a bimetallic element adapted to be heated by the ensuing discharge and engageable with the remaining electrode to short-circuit the discharge path and extinguish the discharge.

8. A gaseous electric discharge device comprising a container provided with an ionizable medium therein, electrodes in said container provided with a coating which emits a copious flow of electrons when heated and between which a discharge occurs upon the application of a suitable potential to said electrodes, contact terminals carried by said electrodes, and one of said electrodes being a bimetallic element adapted to be heated by the ensuing discharge and operable to cause the contact terminal carried thereby to engage the contact terminal carried by the other of said electrodes to short-circuit the discharge path and extinguish the discharge between the electrodes.

9. A gaseous electric discharge device for connecting a load to a source of electrical energy comprising a container provided with an ionizable medium therein, normally spaced electrodes in said container connected respectively to said source and to said load and provided with an electron emissive material and between which a glow discharge occurs upon the application of a suitable potential to said electrodes, and one of said electrodes being a bimetallic element heated by the ensuing discharge and operable to contact the remaining electrode to extinguish the discharge and complete the circuit to said load.

10. A gaseous electric discharge device for making and breaking a circuit to a load comprising a container provided with an ionizable medium therein, normally spaced electrodes in said container connected respectively to said source and to said load and provided with an electron emissive coating supplying a copious flow of electrons when heated and between which a glow discharge occurs upon the application of a suitable potential to said electrodes, and one of said electrodes being a bimetallic element heated by the ensuing discharge and operable to contact the remaining electrode to extinguish the discharge and complete the circuit to said load, and for thereafter interrupting said load circuit upon cooling of said bimetallic element.

11. The combination of a gaseous electric discharge lamp provided with electrodes therein, one of which is adapted to be heated to an electron emitting temperature from a source of electrical energy and having a filling of a readily ionizable medium, a source of electrical energy connected to one of the electrodes of said lamp, an inductance element connected to said source and to the other of said electrodes, and an auxiliary discharge device provided with electrodes connected to the electrodes of said lamp and between which a discharge occurs upon the application of a potential thereto from said source, said device including a bimetallic element disposed therein and heated by the ensuing discharge to cause extinguishment of the discharge and operable to connect the electrodes of said lamp to said source for heating the same to an electron emitting temperature, and said bimetallic element being operable upon cooling thereof to interrupt the heating circuit for the electrodes of said lamp and to cause an attendant voltage surge from said in-

ductance element for initiating a discharge in said lamp.

12. A gaseous electric discharge device comprising an envelope, a pair of electrodes supported in said envelope in a normal predetermined space relation, one of said electrodes being adapted to emit electrons, an ionizable medium in said envelope at such a pressure that a relatively low voltage will cause a glow discharge between said electrodes when disposed in said normal spaced relation, and means operable in response to a discharge between said electrodes for automatically varying the spacing between said electrodes to extinguish said discharge and cause closure of an electric circuit.

13. A gaseous electric discharge device comprising an envelope having electrodes therein, supporting members for normally maintaining said electrodes in a predetermined space relation, one of said electrodes being adapted to emit electrons, an ionizable medium in said envelope at such a pressure that a relatively low voltage will cause a glow discharge between said electrodes when disposed in said normal spaced relation, and means associated with one of said support members for automatically moving the electrode mounted thereon to vary the space between said electrodes sufficiently to terminate the discharge therebetween and cause said movable electrode to complete an electric circuit.

14. A gaseous electric discharge device comprising a container provided with an ionizable medium therein, electrodes in said container, one of which is provided with a material which emits a copious flow of electrons and between which electrodes a discharge occurs upon the application of a suitable potential thereto, and one of said electrodes being a bimetallic element provided with a contact terminal and adapted to be heated by the ensuing discharge and operable to cause the contact terminal carried thereby to engage the other of said electrodes to short-circuit the discharge path and extinguish the discharge between the electrodes.

15. A gaseous electric discharge device for connecting a load to a source of electrical energy comprising a container provided with an ionizable medium therein, normally spaced electrodes in said container connected respectively to said source and to said load, and one of said electrodes being provided with an electron emissive material and between which electrodes a glow discharge occurs upon the application of a suitable potential thereto, and one of said electrodes being a bimetallic element heated by the ensuing discharge and operable to contact the remaining electrode to extinguish the discharge and complete the circuit to said load.

16. The combination of a gaseous electric discharge lamp provided with electrodes therein, one of which is adapted to be heated to an electron emitting temperature, a readily ionizable medium therein, a source of electrical energy for heating the said electrodes and for energizing said lamp, an inductance element interposed between said source and one of said electrodes, and an auxiliary discharge device provided with electrodes therein between which a discharge occurs upon the application of a potential from said source and having an element therein heated by the discharge and operable to cause extinguishment of said discharge and initial connection of the electrodes of said lamp in a heating circuit with said source and to thereafter cause interruption of said heating circuit and an attendant voltage

surge from said inductance element for initiating a discharge in said lamp.

5 17. A gaseous electric discharge device comprising a container provided with an ionizable medium therein, electrodes disposed within said container, one of said electrodes being adapted to emit electrons, and between which a discharge

occurs upon the application of a potential thereto, and an element in said container adapted to be heated by the ensuing discharge and operable to cause a short-circuit of said electrodes and extinguishment of said discharge.

EDWARD CHARLES DENCH.

**Disclaimer**

2,200,443.—*Edward C. Dench*, South Orange, N. J. DISCHARGE LAMP CIRCUIT.  
Patent dated May 14, 1940. Disclaimer filed June 14, 1951, by the  
assignee, *Westinghouse Electric Corporation*.

Hereby enters this disclaimer to claims 6, 7, 8, 9, 10, 12, 13, 14, 15, and  
17 of said patent.

[*Official Gazette July 10, 1951.*]

**Disclaimer**

2,200,443.—*Edward C. Dench*, South Orange, N. J. DISCHARGE LAMP CIRCUIT.  
Patent dated May 14, 1940. Disclaimer filed June 14, 1951, by the  
assignee, *Westinghouse Electric Corporation*.

Hereby enters this disclaimer to claims 6, 7, 8, 9, 10, 12, 13, 14, 15, and  
17 of said patent.

[*Official Gazette July 10, 1951.*]